

2.2

Safety luminaires - High degree of protection

Outdoor Wall

2



- For indoor and Outdoor use
- Robust construction from aluminium diecast and high impact resistant cover made of polycarbonate
- Optional with self-regulating battery heater for use at low temperature down to -20°C

Light Source:

2 x 1.6 W LED

Materials:

Diecast aluminum housing

Polycarbonate lens

Lithium ion battery

Installation:

Wall mounting above exit door or along escape routes

Operation:

For maintained and non-maintained operations CGLine+ (Withoutworking in AT mode)

Manual test with magnet

Applications:

Factories, warehouses, underground car parks, workshops, tunnel

Installation on emergency exits inside and outside buildings

The durable cast aluminum along with the high degree of protection (IP65) makes the Outdoor Wall safety luminaire particularly suitable for industrial areas, underground car parks and tunnels. The range has been developed to be mounted on the wall above the safety exits of a building both inside and outside.

For application with low ambient temperature down to -20°C, e.g. outdoors, this luminaire is also available with a self-regulating battery heater.

The use of LEDs, automatic testing and monitoring devices (CGLine+) significantly reduce the operating and maintenance costs of the installation.

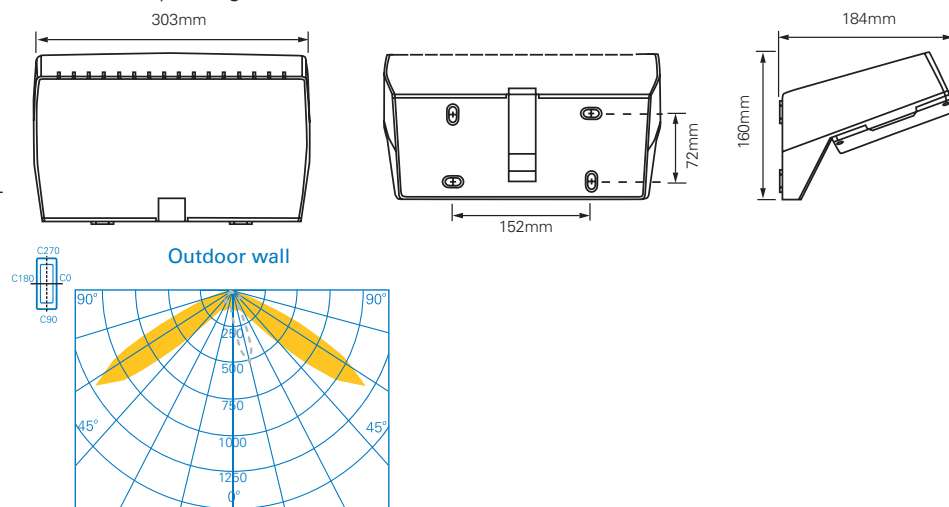

Outdoor Wall light coverage

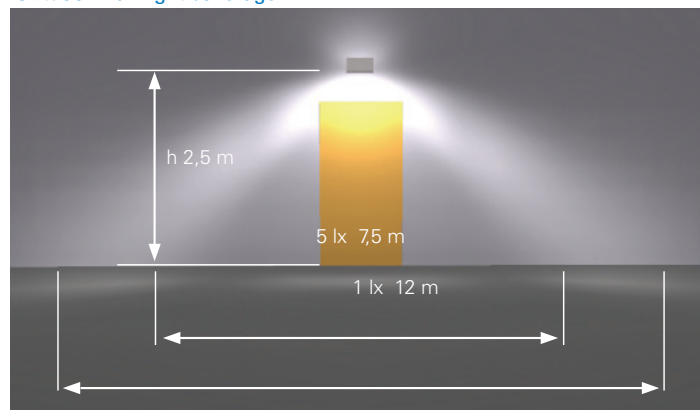

Order code	Description					
40071354874	Outdoor Wall 1-8h CGLine+	7.2 VA/7.0 W	225lm	1 - 3 - 8 h	LiNiMnCoO ₂ 3.7V / 4Ah	Maintained / Non-Maintained
40071354879	Outdoor Wall 1-8h CGLine+ H (with battery heater)	9.2 VA/9.3 W	225lm	1 - 3 - 8 h	LiNiMnCoO ₂ 3.7V / 4Ah	Maintained / Non-Maintained