

EXTENSION ARMS WTM

- **application:** for mounting on poles type SM and SP with spigot ending "E"
- **material:** aluminium alloy anodised in black, there is also the possibility of anodising in other colours

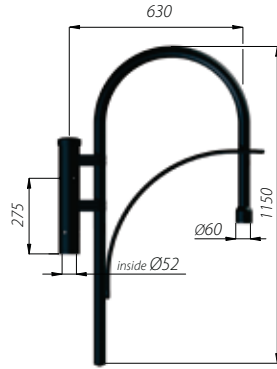

WTM-11/1
code: 476111/C35
luminaires: OP 400, OP 450

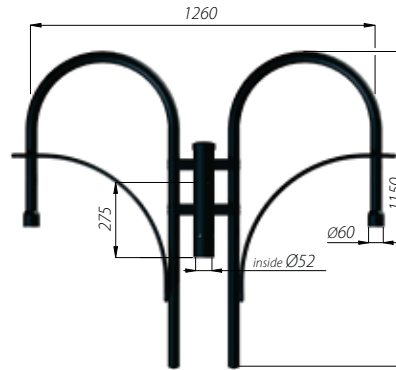

WTM-11/2
code: 476112/C35
luminaires: OP 400, OP 450



WTM-15/1P
code: 476151/C35
luminaires: OP 400, OP 450

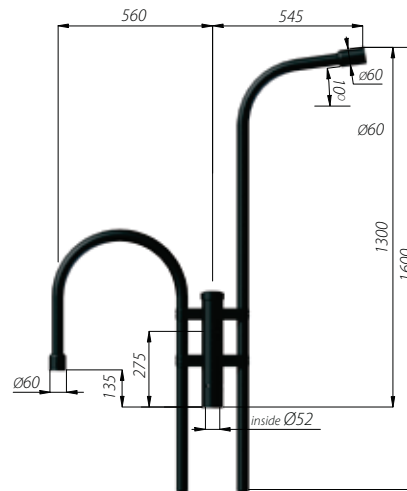

WTM-15/2
code: 476152/C35
luminaires: OP 400, OP 450, street



EXTENSION ARMS WTM

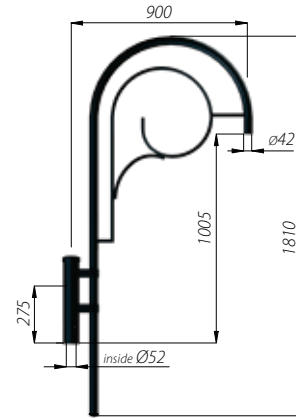

WTM-20/1
code: 476201/C35
luminaires: OW, DROP

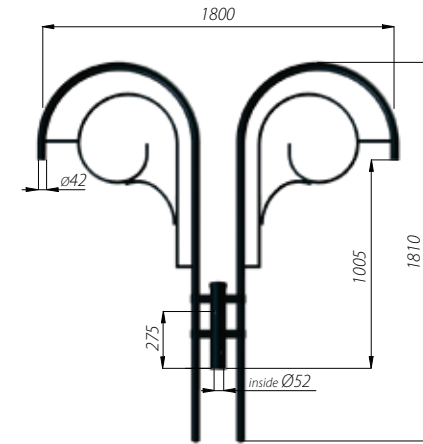

WTM-20/2
code: 476202/C35
luminaires: OW, DROP

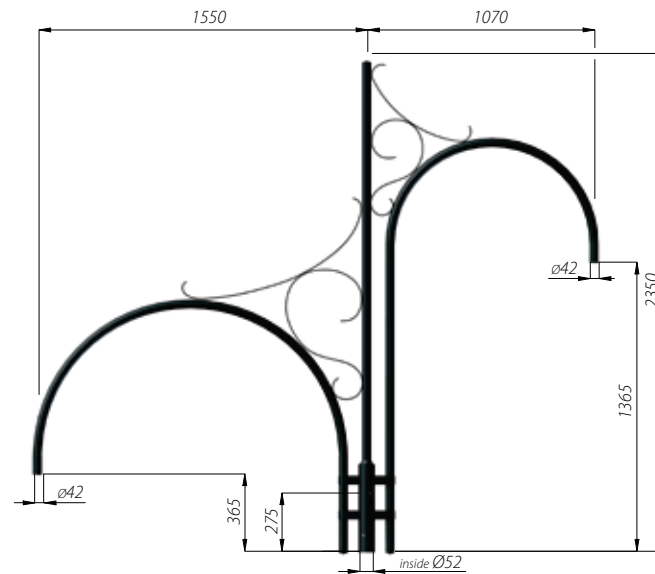

WTM-16/2
code: 476162/C35
luminaires: OW, DROP

PARK LIGHTING